

VRLA Rechargeable Battery

BC200-12



FEATURES

- Maintenance free(no water topping-up required)
- No free acid(Non-spillable battery)
- Can be used in any orientation(excluding used inverted)
- Flame-arrestor is installed to ensure safety
- Carry handles for easy installation
- Absorbent Glass Mat technology for efficient gas recombination

APPLICATION

- UPS
- Telecom



SPECIFICATIONS

Nominal Voltage	12V
Nominal Capacity	200.0 Ah @ 20 hour rate F.V.(1.75V/cell)
Approx. Weight	55.2Kg(121.7lbs.)
Terminals	B9 (Fitting M8 bolt & nut) , I3 is optional
Internal Resistance	≤ 3.0mΩ (Fully Charged)
Max. Discharge Current	800 A (5 sec.)
Max. Charge Current	60 A
Operating Temperature Range	Charge : 0°C~40°C(32°F~104°F) Discharge : -20°C~50°C(-4°F~122°F) Storage : -20°C~40°C(-4°F~104°F)
Container Material	Standard: ABS(UL 94-HB) BC200-12 Optional: Flame Retardant ABS(UL 94-V0) BC200-12FR



- IEC 60896-21/22
- JIS C 8704-2
- GB/T 19638.2

DIMENSION(mm/inch)

OUTER DIMENSIONS

TERMINAL TYPE

- **Length**
522±2.0 (20.55±0.08)
- **Width**
202±2.0 (7.95±0.08)
- **Container Height**
216±2.0 (8.50±0.08)
- **Total Height**
B9:240±2.0 (9.45±0.08)
I3:220±2.0 (8.66±0.08)

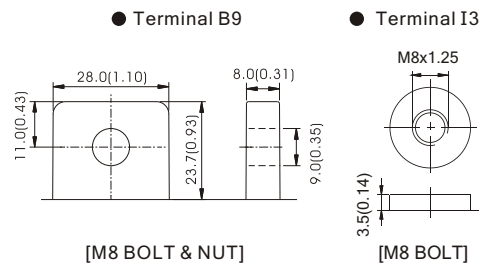
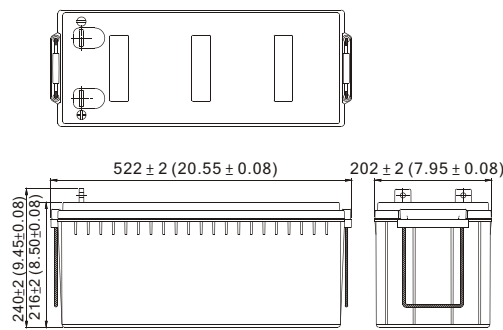

Terminal Hardware Initial Torque: B9,I3(10.0Nm±5%)

Constant power discharge characteristics at 25 °C/77 °F Unit: W

F.V. (V/cell) \ Discharge Time	15 Min	30 Min	1 Hr	3 Hr	5 Hr	10 Hr	20 Hr
1.80V	3346.2	2266.8	1426.4	583.0	402.0	224.6	118.2
1.75V	3499.2	2354.2	1469.2	594.6	408.0	228.0	120.0
1.70V	3605.4	2407.4	1495.6	600.0	410.2	229.2	120.6
1.65V	3690.0	2441.6	1513.8	604.2	411.6	229.8	121.0
1.60V	3762.0	2466.2	1528.8	607.8	412.8	229.8	121.0

Constant current discharge characteristics at 25 °C/77 °F Unit: A

F.V. (V/cell) \ Discharge Time	15 Min	30 Min	1 Hr	3 Hr	5 Hr	10 Hr	20 Hr
1.80V	299.0	194.0	119.8	48.6	33.6	18.8	9.8
1.75V	312.6	201.4	123.4	49.6	34.0	19.0	10.0
1.70V	322.4	206.2	125.8	50.0	34.2	19.2	10.0
1.65V	329.8	209.0	127.2	50.4	34.4	19.2	10.0
1.60V	336.4	211.0	128.4	50.6	34.4	19.2	10.0

All data and artworks shall be changed without prior notice, BB reserves the right to explain and update the information contained hereinto.

For operation, please refer to the instruction from technical manual.

A/0 REV. Mar. 2014

Powered by **B.B. Battery Co., Ltd.**