

# ZELUS

## GEL Technology Battery

— GFT

# GFT 12/110

## 12V, 110Ah/C<sub>10</sub>

### FEATURES

- GFT was designed with solid lead plated and gelled electrolyte technology.
- A deep-cycle lead-acid battery is designed to deliver a maximum capacity and cycles as discharging.
- High temperature stability, mechanical strength and low acid displacement.
- Superior performance with deep discharges.
- Patented safety valve to have accurate pressure operating for long battery life.

### APPLICATIONS

- UPS
- Security
- Telecommunication
- Electronic Medical Equipment
- Emergency Lighting



### SPECIFICATIONS

Nominal Voltage	12 V
Nominal Capacity	110 Ah @ 10 hour rate F.V.(1.80 V/cell)
Approx. Weight	44.5Kg(98.10lbs.)
Terminals	L1 (M8 Male Stud)
Internal Resistance	≤7mΩ (Fully Charged )
Max. Discharge Current	800 A (5 sec.)
Max. Charge Current	22.0 A
Self Discharge	< 2% per month (25°C)
Operating Temperature Range	-20°C~55°C(-4°F~131°F)
Container Material	Standard: ABS( UL94 HB) GFT12/110 Optional: Flame Retardant ABS(UL94 V-0) GFT12/110FR



MH19884



C4M20310-2474-E-16

- GB/T 19638.2-2005
- IEC60896-21/22 2004

### DIMENSION(mm/inch)

### OUTER DIMENSIONS

### TERMINAL TYPE

- **Length**  
560±2.0 (22.05±0.08)
- **Width**  
125±2.0 (4.92±0.08)
- **Container Height**  
255±2.0 (10.04±0.08)
- **Total Height**  
255±2.0 (10.04±0.08)

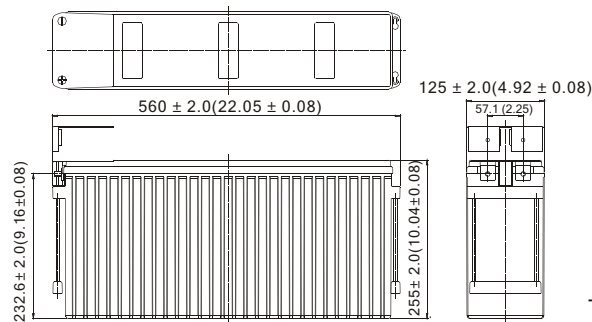

### TERMINAL TYPE

- Terminal L1

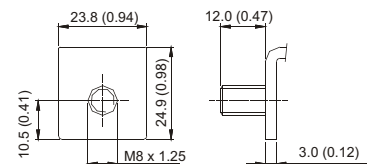

Terminal Hardware Initial Torque: 10.0Nm±5%

### Constant power discharge characteristics at 25 °C/77 °F

Unit: W

Discharge Time F.V. (V/cell)	30 Min	1 Hr	3 Hr	5 Hr	10 Hr	20 Hr
1.80V	1311	764	333.5	235.2	132.0	69.32
1.75V	1334	787	340.2	238.7	133.7	70.38
1.70V	1347	804	344.3	240.8	134.8	70.93
1.65V	1359	813	347.0	241.6	135.1	71.13
1.60V	1363	821	348.8	242.3	135.2	71.15

### Constant current discharge characteristics at 25 °C/77 °F

Unit: A

Discharge Time F.V. (V/cell)	30 Min	1 Hr	3 Hr	5 Hr	10 Hr	20 Hr
1.80V	112.4	65.1	27.93	19.66	11.00	5.777
1.75V	114.7	67.1	28.49	19.96	11.14	5.865
1.70V	116.1	68.5	28.84	20.13	11.23	5.911
1.65V	117.6	69.3	29.06	20.20	11.26	5.928
1.60V	118.1	70.0	29.21	20.26	11.27	5.929

All data and artworks shall be changed without prior notice, BB reserves the right to explain and update the information contained hereinto.

For operation, please refer to the instruction from technical manual.

Trial A/4 REV. Apr. 2021

Powered by

B.B. Tech(Changsha) CO.,LTD